



**SMARTSIDE®**  
TRIM & SIDING

## ARCHITECTURAL COLLECTION CEDAR SHAKE 76 SERIES LAP SIDING

### GENERAL

- At the time of manufacture, siding meets or exceeds the performance standards set forth in Composite Panel Association ANSI 135.6 and has achieved code recognition under Legacy National Evaluation Report NER-626 and CCMC 12353. For copies of these reports, call LP Customer Support at 1-800-648-6893.
- Minimum 6 in. clearance must be maintained between siding and finish grade.
- Siding applied adjacent to porches, patios, walks, etc. must have a clearance of at least 1 in. above any surface.
- Minimum 1" clearance at intersection with roof line
- Apply siding in a manner that prevents moisture intrusion and water buildup.
- All exposed wood substrate must be primed and painted in a manner that prevents moisture intrusion and water buildup.
- In non-traditional ICF and SIP assemblies, the ICF or SIP manufacturer must prescribe the fastening specifications. Note: LP does not recommend LP SmartSide for use in these non-traditional assemblies. If used, LP will not warrant for Buckling and Shrinkage. However, balance of warranty does remain intact.
- DO NOT USE STAPLES
- SIDING MUST NOT BE IN DIRECT CONTACT WITH MASONRY, CONCRETE, BRICK, STONE, STUCCO OR MORTAR.

### STORAGE

- Store off the ground well supported, on a flat surface, under a roof or separate waterproof covering
- Keep siding clean and dry. Inspect prior to application.

### STUD SPACING

- Siding may be applied over sheathed walls or where building codes permit, directly to studs spaced no greater than 16 in. O.C. that have adequate corner bracing.
- In all installations over masonry or concrete walls, the wall shall be furred out and open at the top and bottom of the wall to allow for convective ventilation between framing spaced 16 in. O.C. The framing shall be of adequate thickness to accept 1-1/2 inches of nail penetration. A properly installed breathable water-resistant barrier is required between the siding and masonry or concrete walls.

### MOISTURE

- Moisture control and water vapor control are critical elements of proper housing design. Check your local building codes for application procedures for handling moisture and water vapor in your area.
- When using wet blown cellulose insulation, the insulation must not be in direct contact with the siding and it must be allowed to dry a minimum of 24 hours or longer if specified by the insulation manufacturer.
- As with all wood products, do not apply engineered wood siding to a structure having excessive moisture conditions such as drying concrete, plaster, or wet blown cellulose insulation. If such conditions exist, the building should be well ventilated to allow it to dry prior to the application of the siding.
- Siding must not be applied to green or crooked structural framing members. Do not apply siding over rain-soaked or buckled sheathing materials.
- Gutters are recommended for control of roof water run off.

### SECONDARY WATER-RESISTANT BARRIER

- A properly installed breathable water-resistive barrier is required behind the siding. Consult your local building code for details.
- LP will assume no responsibility for water penetration.

### GAPS & SEALANTS

- Seal all gaps with a high-quality, non-hardening, paintable sealant. Follow the sealant manufacturer's instructions for application.
- Use a high-quality exterior sealant meeting the ASTM C920, minimum Class 25 sealant.

### FLASHING, WINDOWS, DOORS & OPENINGS

- All openings must be properly sealed or flashed in a manner that prevents moisture intrusion or buildup. Several examples that accomplish this are shown on the following pages.

### TRIM

Trim should be thick enough so the siding does not extend beyond the face of the trim.

- Trim and fascia must be applied in a manner that will not allow moisture intrusion or water buildup.
- LP® SmartSide® siding is not designed and/or manufactured to be used as trim or fascia. LP SmartSide trim and fascia are available in a variety of dimensions.

## KICK-OUT FLASHING

- Install kick-out flashing to direct the water into the gutter
- Install step flashing with minimum 4 in. upper leg
- Properly integrate flashing with the secondary water-resistive barrier. Use housewrap, flashing tape, z-flashing, or other items as needed to maintain the counterflashing principle.
- DO NOT extend the siding or trim into the kick-out flashing or gutter
- Maintain a clearance between the end of the gutter and the adjoining wall to allow for proper maintenance of the siding
- Prime and paint ALL exposed cut edges

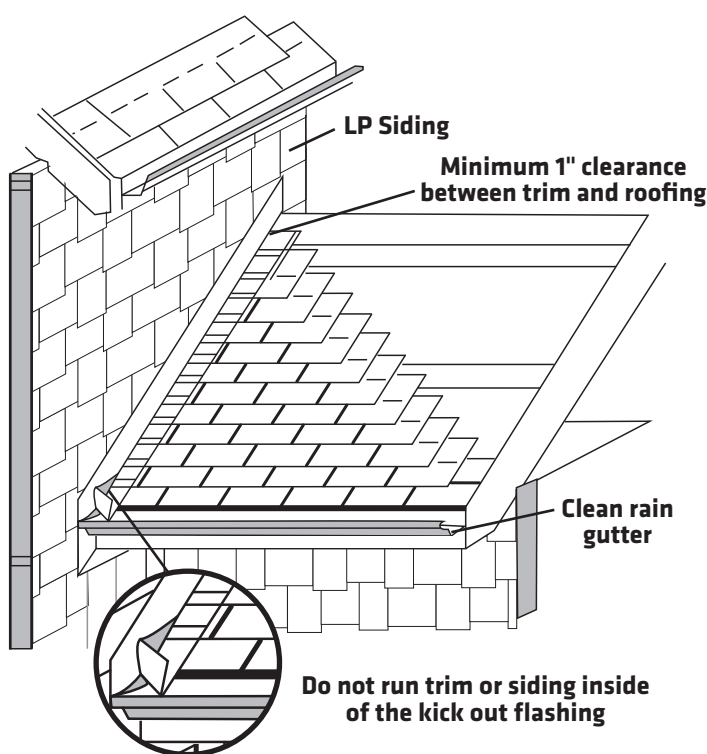

## FINISHING INSTRUCTIONS

- DO**
- **Prime and paint all exposed surfaces including all drip edges or where water will hang.**
  - Apply finish coat as soon as possible or within 180 days of application.
  - High-quality acrylic latex paint, specially formulated for use on wood and engineered wood substrates, is highly recommended. Semi-gloss or satin finish oil or alkyd paints are acceptable. For flat alkyd paint, please check with the coating manufacturer for their recommendations for use on composite wood siding.
  - Follow the coating manufacturer's application and maintenance instructions.

## DO NOT USE

- Semi-transparent and transparent stains.
- Shake and shingle paints.
- Vinyl-based resin formulas such as vinyl acetate, PVA, vinyl acetate/acrylic copolymer paints.

**HANDLE PREFINISHED LP SMARTSIDE PRODUCTS WITH EXTREME CARE DURING STORAGE AND APPLICATION. TOUCH UP ANY DAMAGE TO THE FINISH THAT MAY OCCUR DURING APPLICATION PER PREFINISHERS SPECIFICATIONS.**

## NAILING INSTRUCTIONS

- Apply siding to wall assemblies with stud spacing no greater than 16 in. O.C. Fasten the siding at each stud according to the following steps.
- Begin by nailing a starter strip (approximately 3/8 in. x 1-1/2 in.), flush with bottom edge of sill plate.

**For random drip edge:** Starting from left to right, level and install the first course of siding so random edge is no more than 1/2 in. below the shim. Trim left edge so that siding section fits against corner board, with a 3/16 in. gap, and so that opposite shiplap edge falls on a stud for nailing.

**For straight drip edge:** Starting from right to left, level and install the first course of siding so straight edge is no more than 1/2 in. below the shim. Trim right edge so that siding section fits against corner board, with a 3/16 in. gap, and so that opposite shiplap edge falls on a stud for nailing.

Use "alignment notch" in shiplap edge as automatic guide to lap each siding course. Lap a minimum of 1-3/4 in. to bottom of notch, as shown. Nail 3/4 in. from bottom edge to penetrate both siding courses.

- Start subsequent courses in same manner but trim each course to effect staggered joints. Best appearance is obtained by trimming second course starter piece 16 in. shorter than the first course and trimming the third course starter piece 32 in. shorter than the first. Repeat this same sequence every three courses.
- DO NOT OVERDRIVE NAILS. Nail head should seat firmly to face of siding, but not be overdriven to distort the siding surface.
- All siding joints must fall on studs.
- **At shiplap edges, double nailing is required.**

### CONDITION

### CORRECTION

Snug		OK	
Flush		OK	
Visible fiber		Paint	
Countersunk 1/16-1/8 IN.		Apply sealant	
Countersunk more than 1/8 in.		Apply sealant and re-nail	

- Penetrate structural framing or wood structural panels and structural framing a minimum of 1-1/2 in.
- Use hot-dipped galvanized nails with a minimum 0.270 in. diameter head and 0.113 in. diameter shank.
- Nail at all framing members around openings (maximum spacing 16 in. o.c.). Shim, if necessary, to provide solid backing for siding fitted around windows, doors, and at rake cuts on gable ends.
- Climb cut the surface of the siding such that the rotation of the blade cuts downward on the primed or prefinished surface.
- Where siding butts window trim, door casings and masonry, etc. leave a 3/16 in. gap and seal.
- For information on fastening LP SmartSide products in high wind speed areas, refer to ICC-ES Report ESR-1301 or APA Product Report PR-N124.

#### Insulated Sheathings

LP SmartSide Sidings may be installed over low-compression rigid foam or exterior gypsum. The following precautions must be followed:

- Adequate bracing of the wall in accordance with the International Codes or other ruling building code is required.
- For rigid foam sheathing up to 1 in. (25.4 mm) thick, siding may be nailed directly to the foam sheathing unless a drainage plane is required by the local building code. Nail length must be increased to ensure a minimum 1-1/2 in. (38.1 mm) fastener penetration into the structural framing.
- For rigid foam sheathing greater than 1 in. (25.4 mm), a minimum 1-1/2 in. (38.1 mm) thick by 3-1/2 in. (88.9 mm) wide vertical strapping or furring strip must be installed over the sheathing to provide a solid, level nailing base for the siding. The strapping must be securely fastened to structural framing spaced no greater than 16 in. O.C. (406 mm) with a minimum nail penetration of 1-1/2 in. (38.1 mm) and a maximum nail spacing no greater than the width of the siding.

Louisiana-Pacific will assume no responsibility for any damage or condition arising from the use of rigid foam or exterior gypsum.

The Louisiana-Pacific Corporation ("LP") LP SmartSide Siding (the "Products") limited warranty (the "Warranty") applies only to structures on which the Products have been applied, finished and maintained in accordance with the published application, finishing and maintenance instructions in effect at the time of application. The failure to follow such application, finishing or maintenance instructions will void the Warranty as to the portion of the Products affected by the variance (the "Affected Products").

LP assumes no liability for any loss or damage sustained by the Affected Products and is expressly released by the purchaser or owner from any such loss or liability.

Any modification of the Warranty's application, finishing or maintenance requirements is void and unenforceable unless approved in writing prior to application by the Siding General Manager or his designee and a member of the LP Legal Department.

For a copy of the warranty or for installation and technical support, visit the LP SmartSide product support Web site at:

[www.lpsmartside.com](http://www.lpsmartside.com)

or for additional support call 800-450-6106.

**WARRANTY REMEDIES ARE NOT AVAILABLE IF REQUIREMENTS ARE NOT FOLLOWED.**

---

**Cal. Prop 65 Warning: Use of this product may result in exposure to wood dust, known to the State of California to cause cancer.**

---



©2014 Louisiana-Pacific Corporation. All rights reserved. LP and SmartSide are registered trademarks of Louisiana-Pacific Corporation. Printed in U.S.A.

NOTE: Louisiana-Pacific Corporation periodically updates and revises its product information. To verify that this version is current, call 800-450-6106.

## Roof Flashing Detail

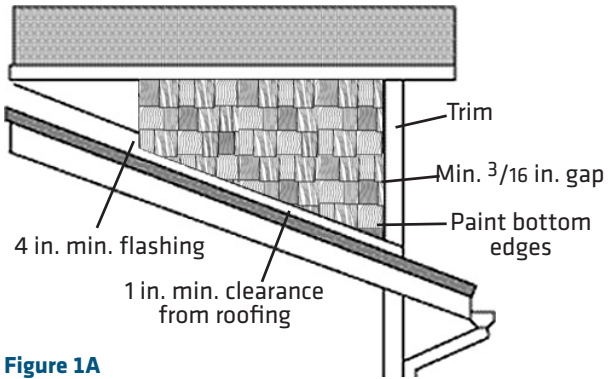

Figure 1A

## Joint Treatment

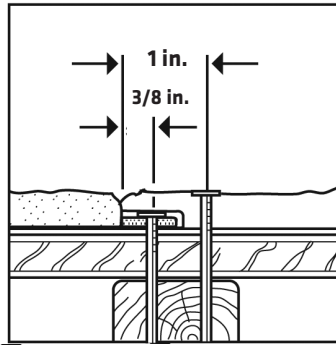

Figure 1B

## Over Openings

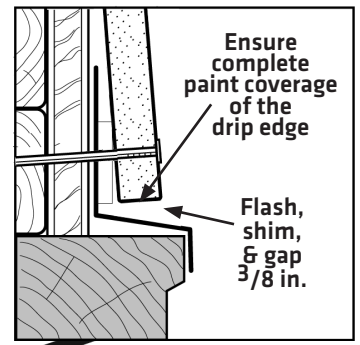

Figure 1C

Figure 1

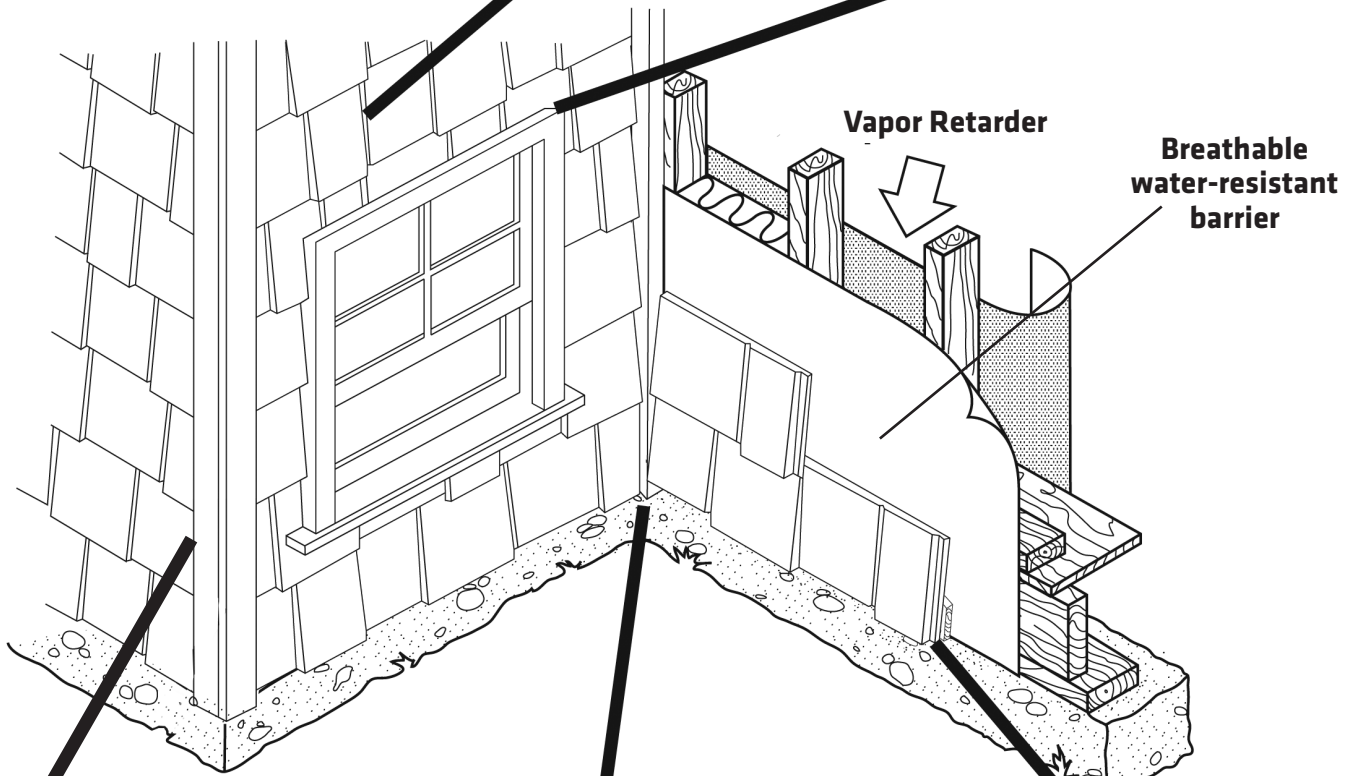
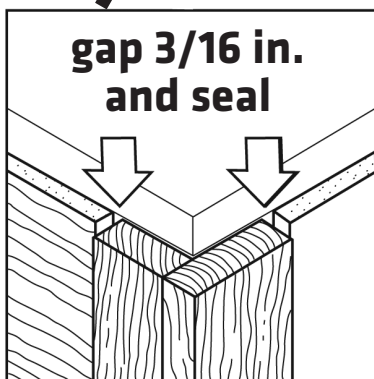

Figure 1F

Figure 1E

Figure 1D



Outside Corner Detail

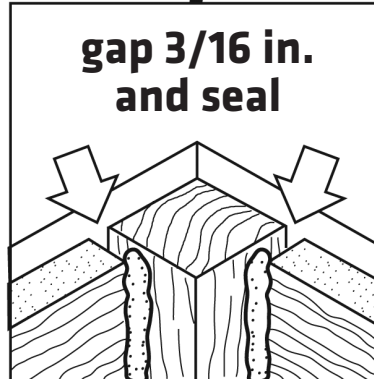

Inside Corner Detail

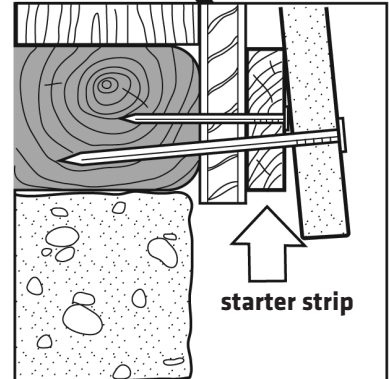

Bottom Course Detail

Figure 2

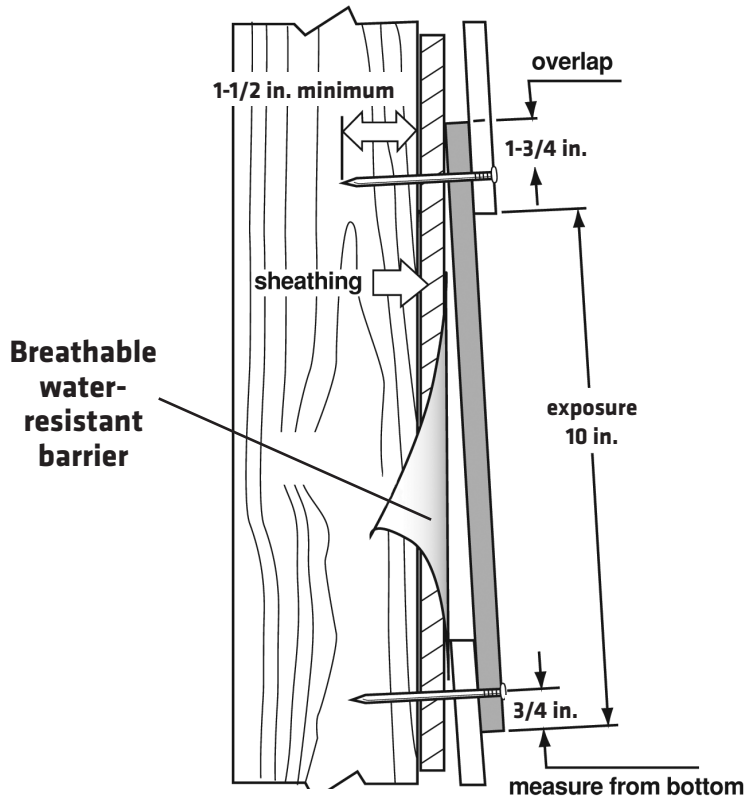
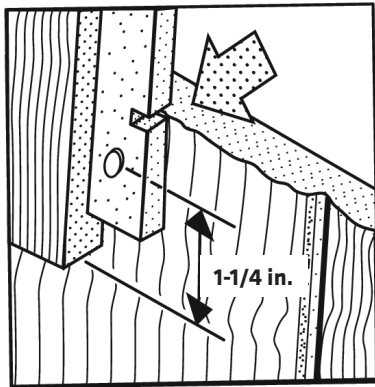

Figure 3



Alignment notch detail

Sheathing and water-resistant barrier

Figure 4

Nailing Detail

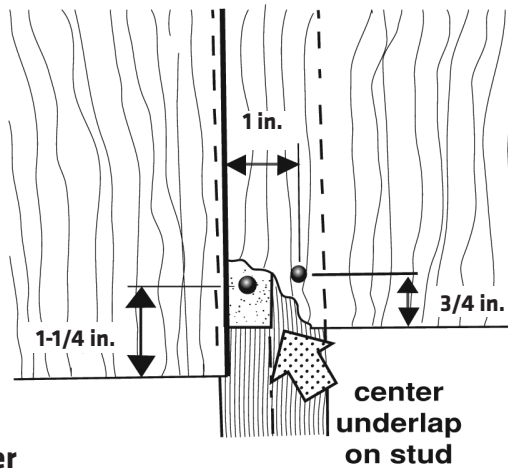
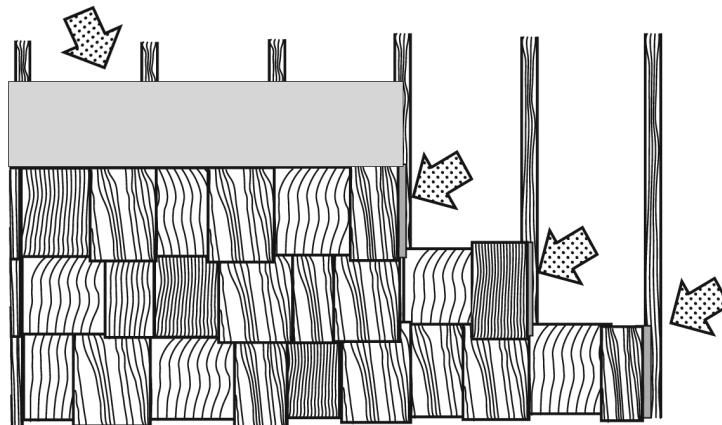

Figure 5



ends of shakes must fall on studs